

48x40 Standard Duty Rackable Pallet

Features & Benefits

- ◆ Injection-fed compression molding technology, utilizing compatibilized materials, delivering superior durability, impact resistance, and optimized performance.
- ◆ Designed with notched stringer sides for 4-way fork entry, enhancing handling efficiency.
- ◆ A superior strength-to-weight ratio ensures maximum carrying capacity and enhanced rigidity for heavier loads.
- ◆ Designed for seamless automation, compatibility with conveyor systems, racking, and stacking.
- ◆ Sustainable production utilizing 100% Green Circle Certified recycled plastic made from post-consumer materials. It is fully recyclable at the end of its life, enabling reuse and contributing to the Circular Plastic Economy.
- ◆ Designed for safe in-store display, ensuring product integrity and customer safety.
- ◆ The molded-in top deck texture enhances the coefficient of friction (COF), helping to prevent product slippage.

Options

- ◆ Available in black only.
- ◆ Hot-stamped logos are available in various color options for customer-specific branding and can be applied on all four sides.
- ◆ RFID capability.
- ◆ Cost-effective leasing options are available.
- ◆ Exclusive buy-back recycling program provides exceptional value at the end of the product life cycle, promoting sustainability and supporting the Circular Plastic Economy.

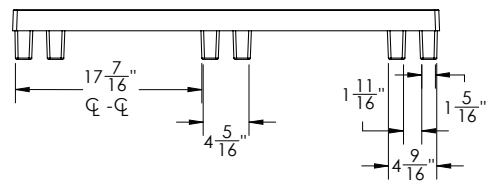
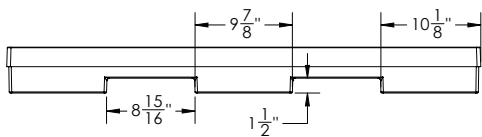
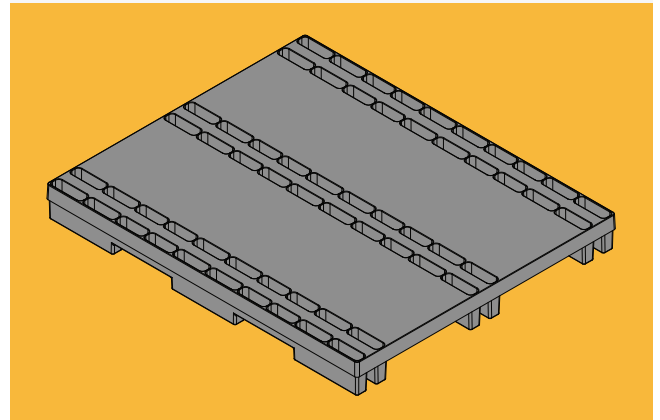

Specifications and Capacities

Length = 48"
 Width = 40"
 Height = 5"

Dynamic load rating = 4,000 lbs.
 Static load rating = 12,000 lbs.
 Racking load rating = 2,500 lbs.

Trailer QTY = 560
 Weight = 42 lbs.